

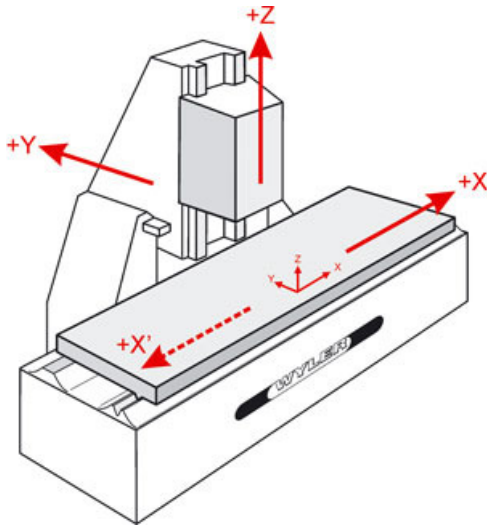

CANADIAN AUTOMATION & TOOL INT. INC.

MACHINERY LIST **CNC HORIZONTAL & VERTICAL MACHINING CENTERS**



- (2) Takumi CNC Vertical Machining Center (Work Area X=87", Y=33.5", Z=29.5")
- (1) Toshiba CNC Vertical Machining Center (Work Area X=52", Y=26", Z =33.5")
- (1) OKK CNC Vertical Machining Center (Work Area X=49", Y=25", Z=24")
- (1) OKK CNC Vertical Machining Center (Work Area X=60", Y=26", Z=25.5")
- (1) Toshiba CNC Horizontal Boring Mill (Work Area X=79", Y=59", Z=57")
14,000 Lb. Rotary Table Capacity
- (1) Toshiba CNC Horizontal Boring Mill (Work Area X=118", Y=90.5", Z =63")
22,000 Lb. Rotary Table Capacity
- (1) Toshiba CNC Horizontal Boring Mill (Work Area X=157.5", Y=92.5", Z=59")
22,000 Lb. Table Load Capacity
- (1) Toshiba CNC Horizontal Boring Mill (Work Area X=64", Y=59", Z=31.5")
6,000 Lb. Rotary Table Capacity
- (1) CRANE CNC Horizontal Boring Mill (Work Area X=157.5", Y=98", Z=78")
25,000 Kg. Table Load Capacity
- (1) TOS Horizontal Boring Mill (Work Area X=220", Y=60", z=36")
- (1) TOS Horizontal Boring Mill (Work Area X=73", Y=63", Z=49")



CANADIAN AUTOMATION & TOOL INT. INC.

MACHINERY LIST

CONVENTIONAL MACHINES

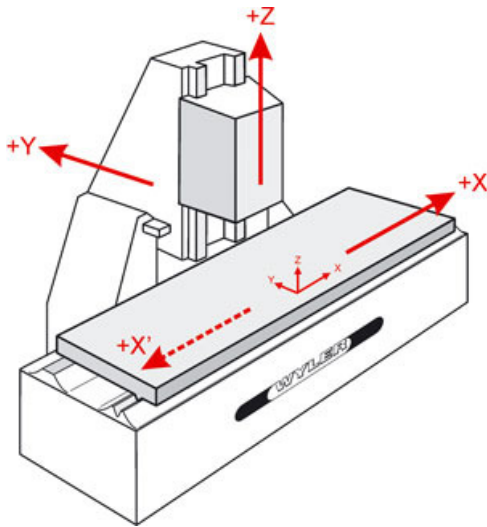

- (1) Mitsubishi Wire Cut E.D.M. Machine (Work Area X= 25.5", Y=29.5", Z=8")
- (1) HSIU Fong Sink Electrical Discharge Machine
- (10) Mig, Tig, Stick Welding Stations
- (9) Bridgeport Type Vertical Milling Machines
- (1) Cincinnati Duty Milling Machine
- (1) Universal Milling Machine
- (3) Lathe Machines: A) 24 Swing X 60" B) 22 Swing X 80" C) 32 Swing X 120"
- (2) Radial Drills with 54" Swing
- (4) Surface Grinders (Work Area 18" X 32")
- (1) Over Head Crane 10 Ton Capacity
- (6) Over Head Crane 15 Ton Capacity